

Astra Tech Implant System® EV

Surgical manual

The Astra Tech Implant System EV is designed for ease of use and versatility in providing treatment solutions for your implant patients.

The foundation of this evolutionary system remains the unique Astra Tech Implant System BioManagement Complex, which has been proven to predictably provide long-term marginal bone maintenance and esthetic results.



Astra Tech Implant System®

CONTENTS

Introduction – Astra Tech Implant System® EV

Drilling protocol and bone classification	4
Implant assortment	4
Implant size/tooth position	5
Interface connection	5
Tray concept	6
Color coding	8

Treatment planning

Pre-operative procedures	9
Clinical application	10

Implant site preparation

Surgical components and instruments overview	12
Implant packaging and handling	16
Drilling protocol	18
Expanded drilling protocol	20
Osteotomy preparation	21
Step-by-step implant placement	22
One-stage surgical protocol	26
Two-stage surgical protocol	27
Step-by-step implant placement, 6 mm	28
Torque Wrench – surgical handling	30
Torque guide	32
Cleaning and sterilization	33

This manual is designed for use by clinicians who have undergone at least basic surgical and in-clinic implant training. Staying current on the latest trends and treatment techniques in implant dentistry through continued education is the responsibility of the clinician.

All products may not be regulatory cleared/released/licensed in all markets. Please, contact the local Dentsply Sirona sales office for current product assortment and availability.

To improve readability for our customers, Dentsply Sirona does not use * or ™ in body copy. However, Dentsply Sirona does not waive any right to the trademark and nothing herein shall be interpreted to the contrary.

Product illustrations are not to scale.

Drilling protocol

The density and orientation of trabeculae in spongy bone differs from patient to patient and from location to location. These variations can create differences in perceived resistance when preparing the implant site and installing the implant. The marginal cortical bone, however, is most often homogeneous in quality but may vary in thickness from case to case, which requires a mandatory adaptive preparation method.

A unique drilling protocol has been developed to allow for preferred primary implant stability. The strategy with the drilling protocol is to provide apical bone support to the implant when indicated, but relieve the apex from bone contact when this support is not indicated.

The stepped osteotomy, providing apical bone support for the implant, is indicated in soft bone situations. In other situations the apical portion of the osteotomy can be widened using the V- or X-drill. The X-drill also widens the body portion of the osteotomy and is indicated in more dense bone situations e.g. in the lower jaw.

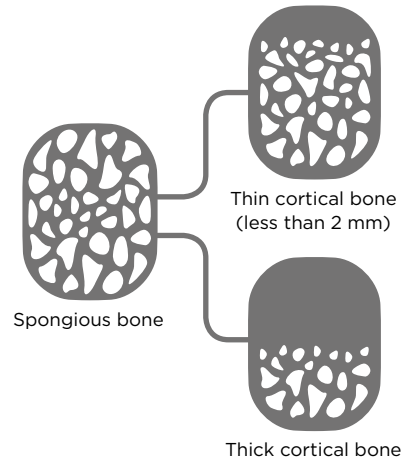

Implant assortment

OsseoSpeed EV implants are available in a versatile range of shapes, diameters and lengths for all indications, including situations with limited space and/or bone quantity.

Specific colors have been assigned to the different implant-abutment connection sizes, which are consistently used throughout the system and identified by symbols and colors.

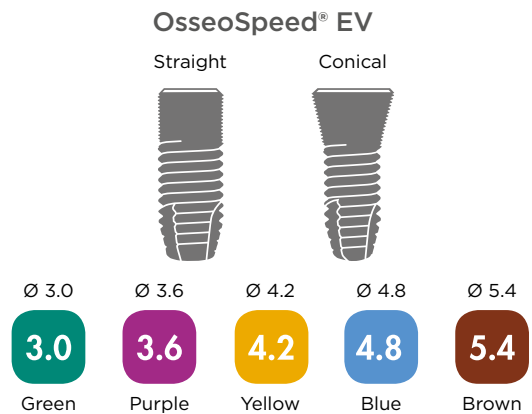

OsseoSpeed® Profile EV

For additional information on OsseoSpeed Profile EV, please refer to the OsseoSpeed Profile EV manual/product catalog.

OsseoSpeed® Profile EV

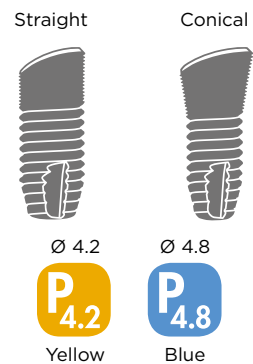

Implant size/tooth position

The design philosophy of the Astra Tech Implant System EV is based on the natural dentition utilizing a site-specific, crown-down approach supported by an intuitive surgical protocol and a simple prosthetic workflow.

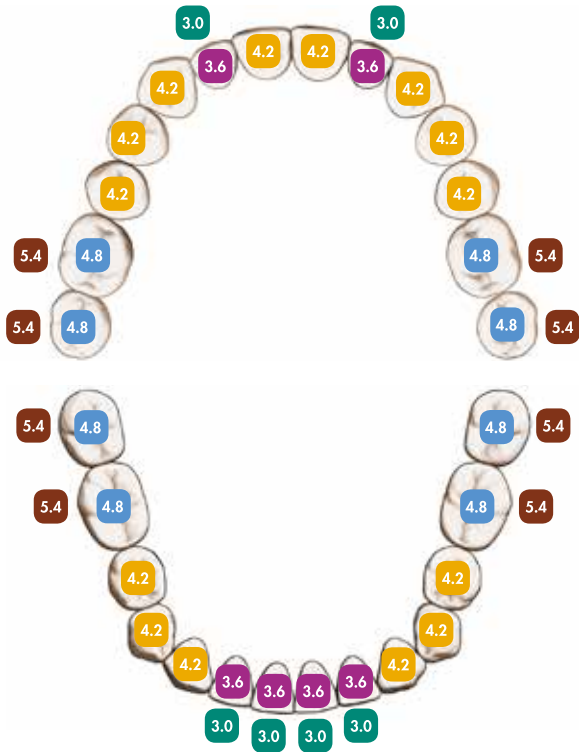

Multiple considerations are required for each tooth replacement, the support needed for the final restoration in the particular position, soft-tissue healing, and implant design and size. The illustration indicates the recommended implant sizes in relation to the natural dentition, provided there is sufficient bone volume and space in relation to adjacent dentition.

Implant-abutment interface connection

The **OsseoSpeed EV** implant has a unique interface with a one-position-only placement for restorative procedures and components, e.g. the Atlantis patient-specific abutments. The interface also allows for the flexibility of six-position indexing of prefabricated abutments, while index-free abutments can be seated in any rotational position.



OsseoSpeed EV

Abutment placement option

One-position-only

Atlantis patient-specific, abutments will seat in one position only.



Six positions

Indexed abutments will seat in six available positions.

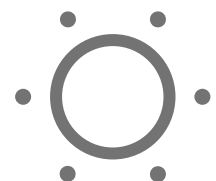

Index free

Index-free abutments will be seated in any rotational position.

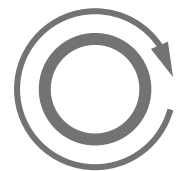

Tray concept

The tray layout and components are organized to support the user throughout the entire surgical procedure. The tray design eliminates the need for rubber grommets for holding drills and instruments, which simplifies the cleaning process.

The layout is printed on the overlay, which is snapped onto the tray base. This solution offers the possibility of adapting the tray's contents according to individual preferences.

Tray logics

The color-coded, large tray has a drill marking system for ease of use and effective handling throughout the procedure, based on the following principles:

- Drills for the spongious bone preparation are color-coded white and marked with drill numbers 1-6 on the drill shaft.
- Drills for the mandatory cortical bone preparation are color-coded according to the implant and marked with either an A or B for straight implants or A/B for conical implants.
- Drills for relieving the apical bone support and widening of the osteotomy are color-coded according to the implant and marked with V or X.
- In addition to the diameter, all drills shafts are marked with a number or letter for easy identification and reference.

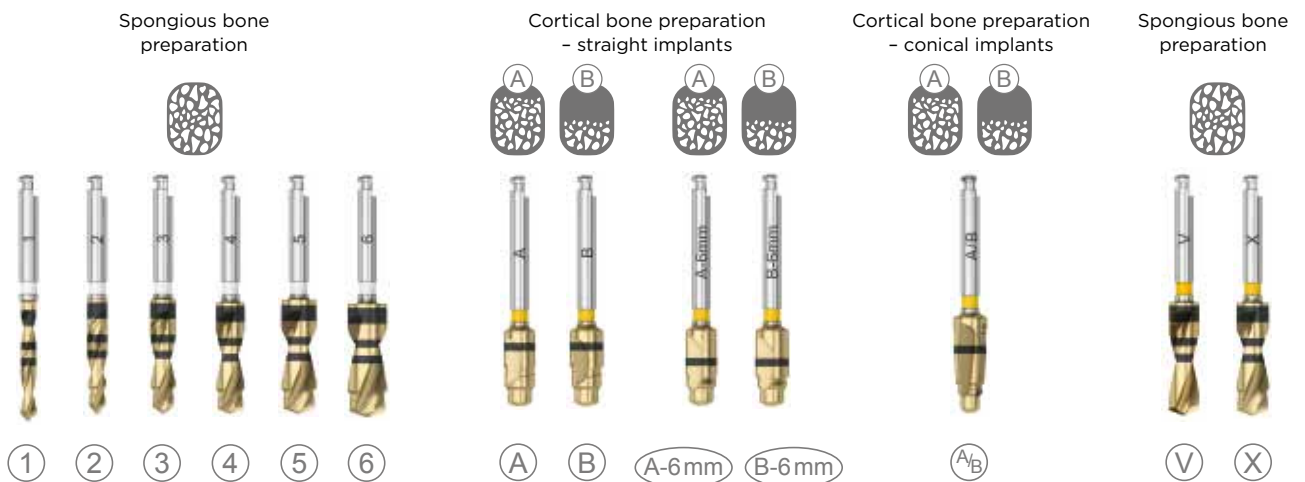
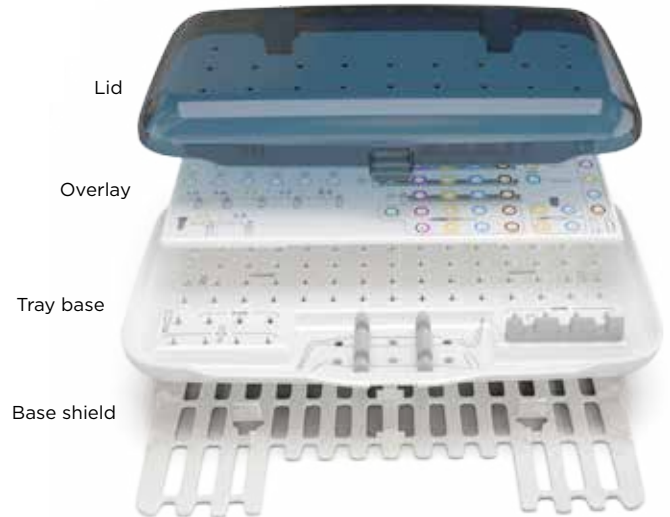



3.6 4.2 4.8

Overlay 1



Streamlined content for the most commonly used straight implants.



3.0 3.6 4.2 4.8 5.4

Overlay 2

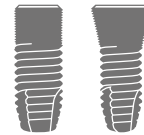

Designed to accommodate the complete range of diameters for straight and conical implants.



3.0 3.6 4.2 4.8 5.4

Overlay 3

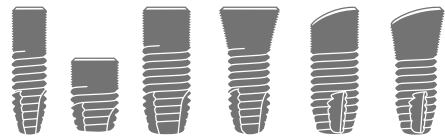

Supports the full implant assortment including short and OsseSpeed Profile EV implants.



Small Tray EV

A flexible, compact and convenient small tray available in three layout options: surgical, restorative and storage.

Color coding

Throughout the Astra Tech Implant System EV, markings, color coding and geometrical designs simplify the correct identification of corresponding components.

Each implant-abutment connection size is identified by a specific color, which is used consistently throughout the system. The color is applied directly to components and instruments, as well as on packaging and informational material, where appropriate.

The following components and/or packaging are color-coded:

Ø 3.0	Ø 3.6	Ø 4.2	Ø 4.8	Ø 5.4
3.0	3.6	4.2	4.8	5.4
Green	Purple	Yellow	Blue	Brown



Healing components



Abutment screws for all two-piece abutments



Packaging for components on implant-level



Impression components on implant-level



Laboratory components on implant-level

Pre-operative procedures

Pre-operative examination

An evaluation of the patient's general and oral health, with clinical and radiographic examinations, must be performed. Particular attention should be given to mucous membranes, jaw morphology, dental and prosthetic history, and signs of oral dysfunction.

Radiographic analysis should be used to evaluate bone topography of the residual alveolar process. The initial radiographic evaluation, together with the clinical examination, is the basis for determining whether or not a patient is a candidate for implant treatment.

If the patient is found to be suitable, a more thorough clinical examination of the area for treatment and the opposing jaw should be performed. Any local pathology in the jaws should be treated before implant placement.

Pre-operative planning

Pre-operative planning should be based on the expected restorative treatment outcome. The Astra Tech Implant System EV assortment is designed to meet the prosthetic needs for the tooth replacement planned. The prosthetic versatility in materials, designs and sizes is aligned with the implant for support of the tooth replacements in the different positions in the jaw.

To achieve the expected outcome, treatment planning should include all stages of the procedure, from healing time and components to provisional and final restorations.

Today, digital processes with CBCT scans, together with optical surface scans, can replace or complement models mounted on an articulator and provide (analog or virtual) information of the relationship between jaws and teeth. A diagnostic wax-up with the missing teeth replaced provides important information in the planning phase. Based on analysis and evaluation of the occlusal table, force distribution and preferred sites for the implants, an optimal plan can be achieved. The transparent Radiographic Implant Guides displaying implants in different magnifications are helpful in planning optimal position, direction and implant size. When working in a digital environment, the planning software provides a library of the different implants.

Implant computer guided implant treatment software can be used for the Astra Tech Implant System EV to ensure accurate planning for optimized implant position and placement.



Even though the final treatment approach may be determined at the time of surgery, consider the following based on the quality of supporting bone and expected initial stability of the implant(s):

- One- or two-stage surgical procedure
- Immediate or early loading protocol
- Expected healing time before loading

When the prerequisites for immediate loading cannot be met, an early loading protocol (at least six weeks healing period) may be considered.

In all situations, bone quality and quantity, primary stability achieved, design of restoration, and loading conditions should be carefully examined and assessed by the clinician when determining time to loading of implants for each individual case.

Before treatment begins, the patient should be informed about the results of the pre-operative examination and given a clear explanation of what is entailed by the planned treatment, including the expected outcome, maintenance requirements and risks involved.





Radiographic Implant Guides

Clinical application

OsseoSpeed EV implants are indicated for immediate placement in extraction sites and/or in partially or completely healed alveolar ridges using a one- or two-stage surgical procedure.

Implants with the OsseoSpeed surface are especially indicated for use in soft bone situations where implants with other surface treatments may be less effective.

OsseoSpeed EV implants can be used in an immediate loading protocol. However, for single-tooth replacement in soft bone or when using a 6 mm implant, where primary implant stability may be difficult to maintain, immediate loading may not be appropriate and thus not recommended.

Implant shape	General clinical application	3.0	3.6
Straight 	Suitable in the majority of situations.	For replacement of maxillary lateral and mandibular central and lateral incisors when there is not enough space for a wider implant.	Used in situations with limited bone volume or space between adjacent teeth, where a 4.2 mm implant is judged to be too wide.
Conical 	In situations with limited bone volume where a larger prosthetic platform is preferred.	N/A	N/A

Precaution: When treatment planning for implant with 6 mm length consider the widest possible implant, a two-stage surgical approach and splinting of implants. Closely monitor the patient for peri-implant bone loss or change in the implants' response to percussion. If the implant shows greater than 50% bone loss or mobility, consider possible removal of implant.

Based on mechanical strength considerations, it is recommended to always place the widest implant possible for the edentulous space. This is particularly important in the posterior regions of the jaws where loading forces are high and considerable bending moments could be generated.

In all cases, it is important to consider loading conditions when determining the number and spacing of implants.

4.2	4.8	5.4
Suitable in the majority of situations.	Used in situations with enough bone volume.	Suitable in situations with wide ridges and large edentulous spaces.
Suitable in situations with limited bone volume where a 3.6 mm implant diameter is the choice but where a larger prosthetic platform is preferred.	Suitable in situations with bone volume where a 4.2 mm implant diameter is the choice but where a larger prosthetic platform is preferred.	N/A

Surgical components and instruments overview

Implant sites are prepared in a step-by-step procedure using different diameter drills, instruments and verification tools, ensuring an efficient and atraumatic preparation. All drilling in the bone should be performed at a maximum of 1500 rpm using profuse external irrigation with a saline solution. An intermittent drilling technique will help prevent heating of the bone and create a pumping effect for efficient removal of bone tissue.

Astra Tech Implant System EV drills:

- Excellent cutting properties
- Laser-etched depth indication lines
- Sterile packaging
- Multiple-use* with option for single-use
- In addition to the diameter, all drills shafts are marked with a number/letter for easy identification and reference
- Color-coded



Packaging

- Open the package.
- Pour the blister onto a sterile area.
- Secure the drill by squeezing the blister.
- Expose the drill shaft by bending back the top of the blister.

Pick-up

- Engage the drill with the contra angle.

Guide Drill EV / Precision Drill EV

Used for marking and creating a starting point.

Note: The Precision Drill EV is an extremely sharp, single-use-only drill and should never be handled manually once out of its package.

* All drills except Precision Drill EV can be used for approximately ten cases. They should be carefully cleaned and sterilized after each surgery and replaced as soon as a decrease in their cutting efficiency is observed.



Drill packaging*



*Patent pending

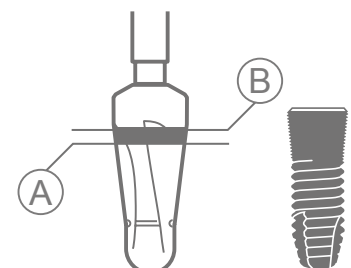
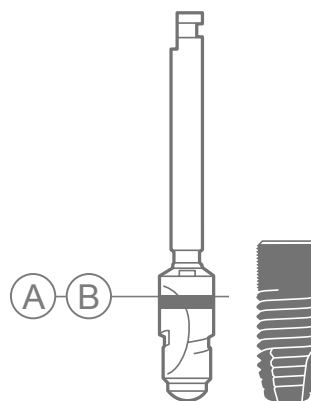
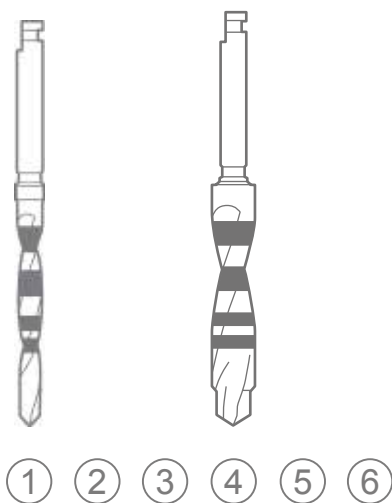

Spongy bone preparation

Twist Drill: Used for initial preparation and evaluation of the bone (1).

Step Drill: Used for site preparation, resulting in a stepped osteotomy with apical bone support for the implant. The drills (2)–(6) provide guidance during the drilling process.

- Color: white
- Markings: diameter and drill number
- Length: available in short (6–13 mm) and long (6–17 mm)

Cortical bone preparation – straight implants

Mandatory preparation of the cortical layer to reduce pressure in the bone around the implant neck.

- Color: corresponds to implant
- Markings: diameter and drill letter
- (A) – thin cortical bone < 2 mm
- (B) – thick cortical bone ≥ 2 mm
- Length: one option

Note: There are separate cortical drills specific for the 6 mm implant.



Cortical bone preparation – conical implants

Mandatory preparation of the cortical layer to reduce pressure in the bone around the implant neck.

Apical border of the indication line indicates the minimum depth needed to fit the implant.

- (A) In thin cortex, drill to the apical border of the depth indication line.
- (B) In thick cortex, drill to the full depth of the depth indication line.

Make sure enough depth is provided for the entire implant.

- Color: corresponds to implant
- Markings: diameter and drill letter
- Length: one option

Surgical components and instruments overview

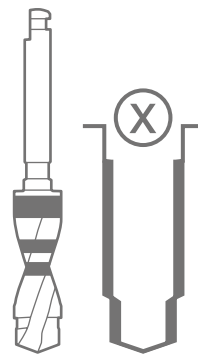
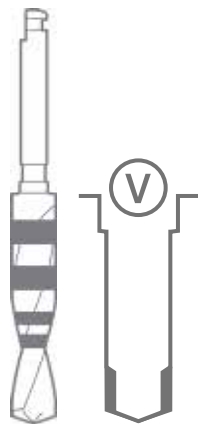

Alternative spongy bone preparation

V-Twist Drill - extra apical preparation

Following the opening of the marginal cortical layer with cortical drill (A), (B) or conical drill (A_b), the (V) drill is used to relieve the apical bone support when this support is not indicated.

- Color: corresponds to implant
Note: for conical implants, this color refers to the implant body diameter.
- Markings: diameter and (V)
- Length: available in short (6 -13 mm) and long (6 -17 mm).

X-Step Drill - extra body preparation

Following the opening of the marginal cortical layer with cortical drill (B) or conical drill (A_b), the (X) drill, in addition to relieving the apical bone support, is used to widen the body portion of the osteotomy in situations with more dense bone e.g. the lower jaw.

- Color: corresponds to implant
Note: for conical implants, this color refers to the implant body diameter.
- Markings: diameter and (X)
- Length: available in short (6 -13 mm) and long (6 -17 mm).

Direction Indicator EV

Used for visualizing the position and direction of the prepared osteotomy.

The narrow end is used after drill ① and the wider end is used after drill ③.

A laser marking indicates the 6 mm depth. The flange (collar) of the instrument indicates the smallest (3.0) and greatest (5.4) implant platform size.

Direction Indicator EV is equipped with a hole for attaching a safety thread.

Measuring osteotomy depth

Carefully measure the depth of the osteotomy. Use the same clinical reference point for the depth as for the planned implant position.

The depth should allow the implant to be level with or slightly submerged in relation to the adjacent marginal bone.

Drilling depth

The drilling depth is measured from the widest part of the drill tip up to the indication line. Length, available in short (6-13 mm) and long (6-17 mm).

Additional tip depth is maximum 1.0 mm regardless of the drill diameter.



Implant Driver Extender EV-GS

Used for extending the length of a drill shaft.

Note: Ensure sufficient irrigation when using the drill extension.

Implant Depth Gauge EV

Used for measuring the depth of the implant site.

- Markings: corresponds to the implant lengths 6-17 mm

The other end of the gauge can be used as a measuring probe.

- Markings: 0-15 mm



Note: The depth gauge is designed with waist to facilitate the identification of the 13-15 mm marking.

Implant Driver EV

Used for picking up and installing the implant in the prepared osteotomy. The Implant Driver EV can engage into any of the six positions of the implant. The body of the driver has a hexagonal geometry with dimples.

Note: To facilitate optimal placement of pre-designed abutments, align one of the dimples buccally.

The reference point ("0") of the depth markings is the intended bone level, i.e., the lowest point of the bevel.

- Color: corresponds to implant
- Markings: depth and diameter
- Length: two options

Implant packaging and handling

The packaging includes a 2D barcode for simplified inventory control.



Packaging

- Packages contain protective blisters that hold the components.

Labels

- Three peel-off labels are provided for the patient's treatment record and for communicating with the restorative team.

Implant container

- Open the blister package.
- Pour the sterile inner container onto a sterile area.
- Remove the cap from the container using a twisting motion to expose the top of the implant.

Note: Marked with implant size and length

Implant pick up

- Attach the appropriate Implant Driver EV to the contra angle or Surgical Driver Handle.

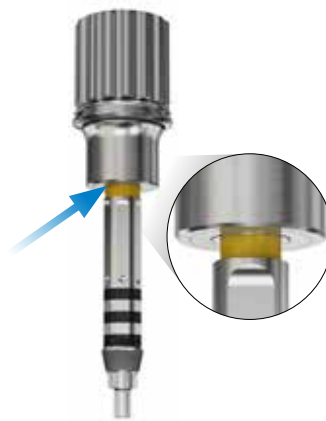
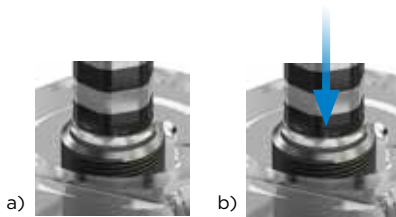

Implant pick up

- Make sure that the implant driver is fully seated into the implant (a).
- Press downwards to activate the carrying function before picking up the implant (b).
- When picking up the implant from the inner container, do not use excessive pressure.

Attach the Implant Driver EV

- Attach the Implant Driver EV by pressing it firmly into the Surgical Driver Handle EV. The driver is correctly seated when the color coded marking is just in contact with the handle.

Manual implant pick up

- Use the Implant Driver EV together with Surgical Driver Handle EV to pick up the implant.

Drilling protocol for OsseoSpeed® EV – straight

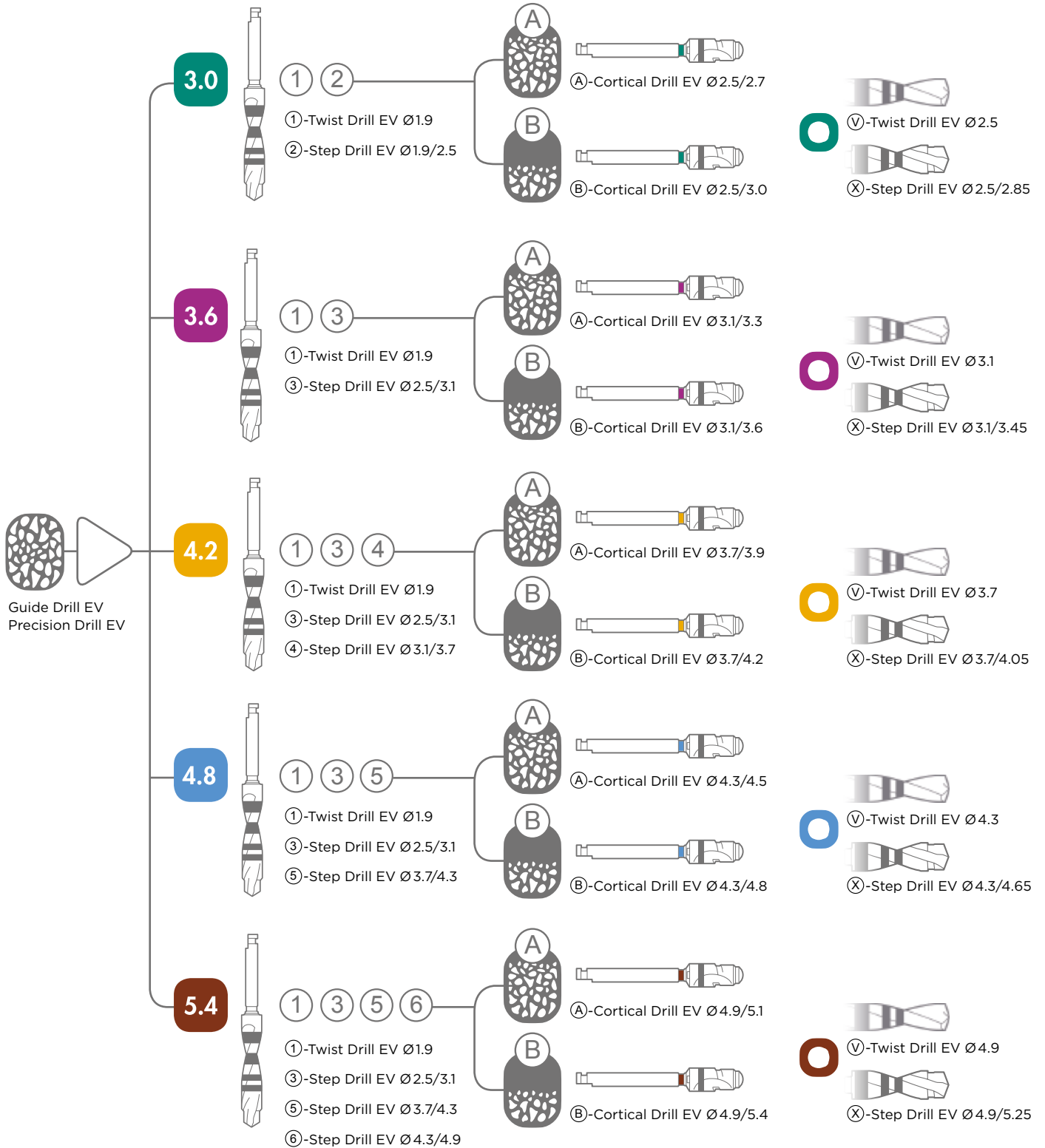

Note: There are separate cortical drills specific for the 6 mm implant.

Drilling protocol for OsseoSpeed® EV – conical



Conical implants are available for situations with limited bone volume where a diameter 3.6 or 4.2 mm implant body is the choice, but where a larger prosthetic platform is preferred.

Note: If an additional spongy bone preparation with V or X drill is performed, use the color that refers to the implant body diameter.

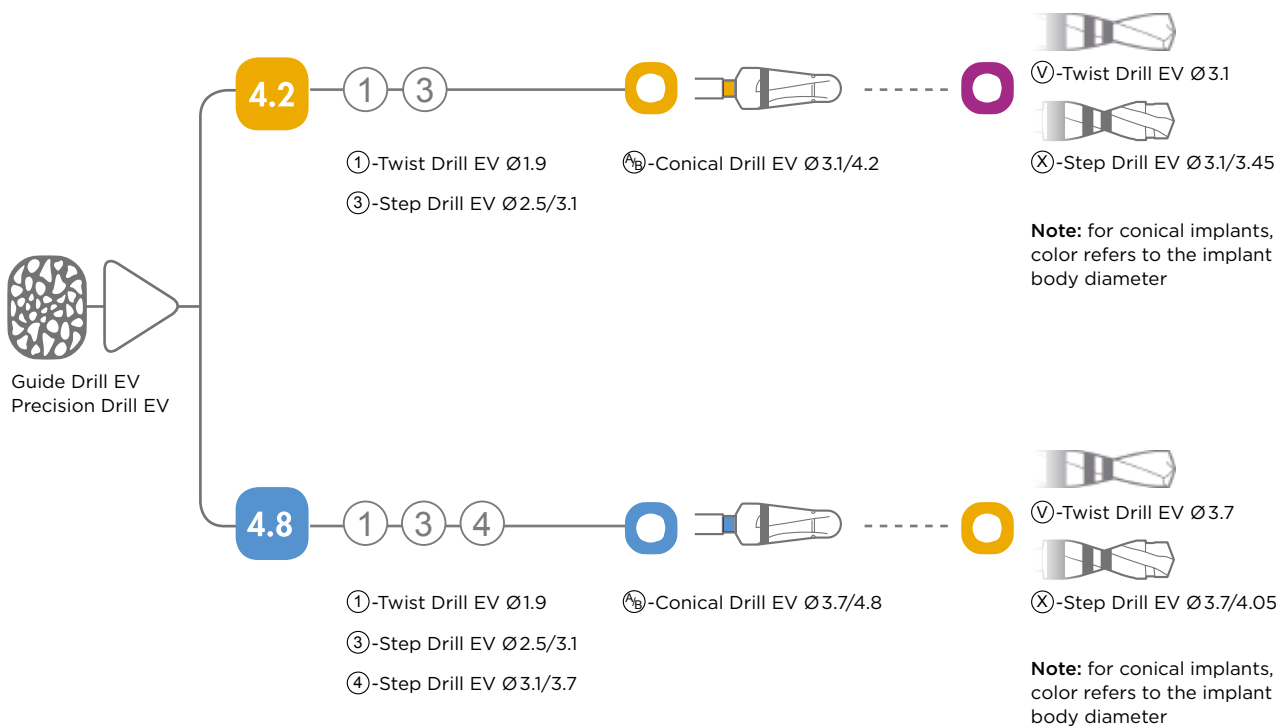

Expanded drilling protocol for OsseoSpeed® EV – straight OsseoSpeed® EV – conical

In sites with compromised bone, the drilling protocol can be expanded to provide further guidance with more drilling steps. This approach is particularly useful in situations with an extremely narrow alveolar ridge (knife-edge).



Note: for conical implants, color refers to the implant body diameter

Osteotomy preparation

Mandatory

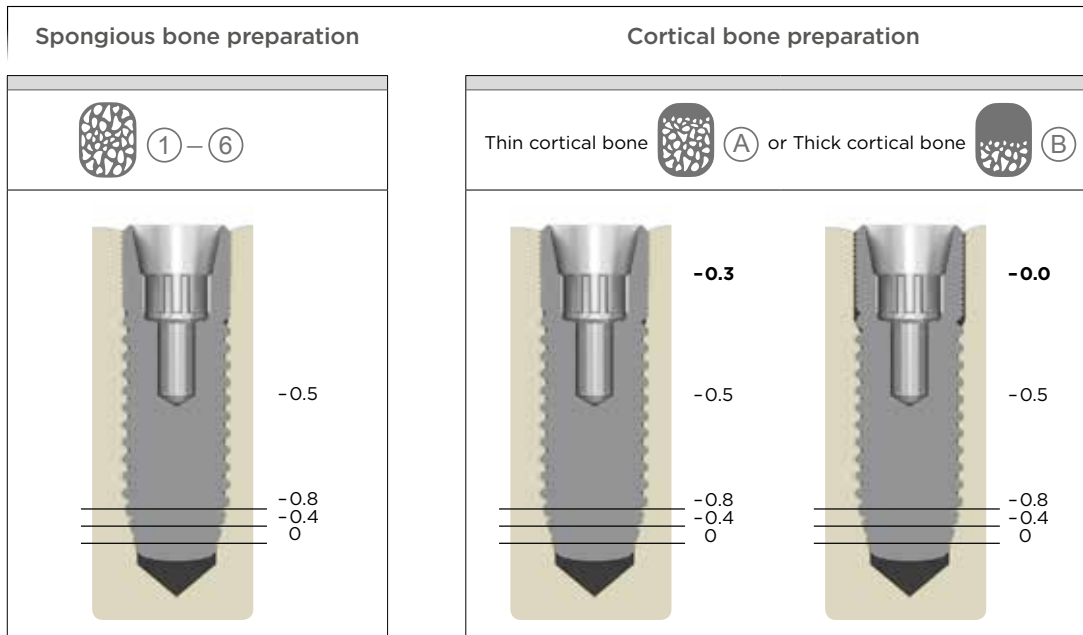

The spongy bone preparation results in an under-preparation compared to the implant diameter of 0.5 mm at the body portion. Corresponding under-preparation at the apex is, from where the apex begins towards the tip of the implant, 0.8, 0.4 and 0 mm respectively.

After completion of the spongy bone preparation, mandatory use of cortical drill (A) or (B) will result in an under-preparation, at the margin, of 0.3 mm or 0 mm respectively compared to the marginal implant diameter.

Alternative*

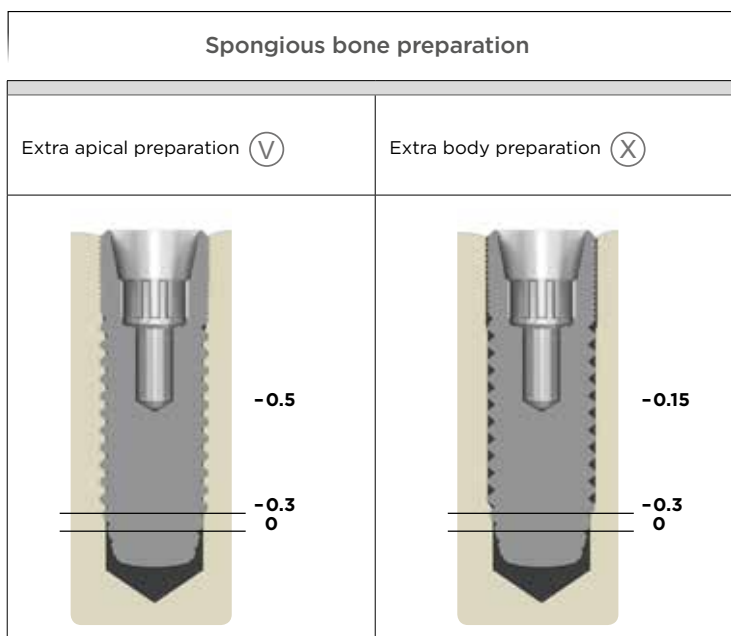

The stepped osteotomy, which provides apical bone support, is indicated in soft bone situations. In other situations the osteotomy can be widened using the (V)- or the (X) drill.

(V) drill: For apical widening use the (V) drill resulting in an apical under-preparation, from where the apex begins towards the tip of the implant, of 0.3 mm or 0 mm respectively at the apex portion.

(X) drill: For body and apical widening use the (X) drill. This results in an under-preparation at the body portion of 0.15 mm. At the apical portion the under-preparation is 0.3 mm or 0 mm respectively from where the apex begins towards the tip of the implant at the apex portion.

*Note: Not recommended in soft bone situations.

Step-by-step implant placement: 4.2 OsseoSpeed® EV



Below is a step-by-step protocol for the preparation and installation of an OsseoSpeed EV 4.2 S, 13 mm.

Note: All drilling should be performed at a maximum speed of 1500 rpm with profuse irrigation.



Twist Drill EV 1.9 ①

- An acrylic stent can be useful during the drilling procedure. If preferred, Guide Drill EV or Precision Drill EV can be used to create a pilot hole prior to using the Twist Drill ①.
- Drill in the planned direction to the appropriate depth.
- The drilling will provide valuable information about the cortical and spongy bone.
- Insert the smaller end of the Direction Indicator EV into the site to visualize/verify the direction.

Note: The depth should allow the implant to be level with or slightly submerged in relation to the adjacent marginal bone.

Step Drill EV 2.5/3.1 ③

- Drill in the planned direction to the appropriate depth.
- Insert the larger end of the Direction Indicator EV into the site to visualize/verify the direction.

Step Drill EV 3.1/3.7 ④

- Drill the implant site to the appropriate depth.

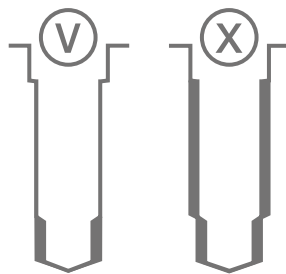

Cortical Drill EV

- Finalize the osteotomy by drilling to the full depth as indicated by the marked line. Use the cortical drill based on the cortical bone thickness:

Cortical Drill (A) 
for a thin cortical bone

Cortical Drill (B) 
for a thick cortical bone

Additional spongy bone preparation

- When deemed necessary, the preparation can be performed with either of the following drills:

(V) Twist Drill EV

Following the opening of the marginal cortical layer with cortical drill (A) or (B), the (V) drill can be used to relieve the apical bone support when this support is not indicated.

(X) Step Drill EV

Following the opening of the marginal cortical layer with cortical drill (B), the (X) drill, in addition to relieving the apical bone support, is used to widen the body portion of the osteotomy in situations with more dense bone e.g. the lower jaw.

Measuring the osteotomy depth

- Carefully measure the depth of the osteotomy. Use the same clinical reference point for the depth as for the planned implant position.
- Verify the implant site depth after drilling using the Implant Depth Gauge EV.

Note: The depth should allow the implant to be level with or slightly submerged in relation to the adjacent marginal bone.

Step-by-step implant placement: 4.2



Implant pick up

- Attach the appropriate Implant Driver EV to the contra angle.
- Make sure that the implant driver is fully seated into the implant (a).
- Press downwards to activate carrying function before picking up the implant (b). Do not use excessive pressure.

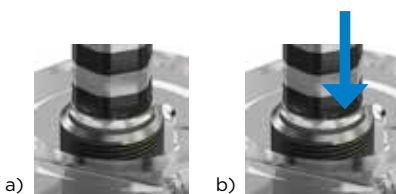

Machine implant installation

- Install the implant with the contra angle at low speed (25 rpm) under profuse irrigation and the maximum torque set to 45 Ncm.
- Allow the implant to work its way into the osteotomy. Avoid applying unnecessary pressure.

Note: Do not exceed 45 Ncm when installing the implant. If not completely seated before reaching 45 Ncm, reverse/remove the implant and widen the osteotomy appropriately (see Additional osteotomy preparation).

It is recommend to have a titanium forceps available in case the implant driver does not provide sufficient carrying function during the removal procedure.

Manual implant installation

- Attach the Implant Driver EV by pressing it firmly into the Surgical Driver Handle EV.
- The driver is correctly seated when the color coded marking is just in contact with the handle.
- Pick up and install the implant.

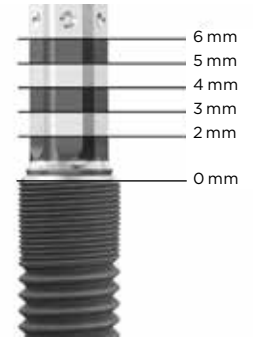

The reference point ("0") for the depth markings is the lowest point of the bevel.



Attach

- Attach the Implant Driver EV and Surgical Driver Handle into the wrench until there is an audible click.

Positioning

- Position one of the dimples on the implant driver buccally to facilitate optimal placement of pre-designed abutments using the Torque Wrench EV together with Surgical Driver Handle.
- Release the implant driver by lifting it gently from the implant.

Finalizing implant installation

- Continue the procedure for finalizing the installation of the implant according to a one- or two-stage approach.

One-stage surgical protocol

HealDesign EV

- Round shapes are indicated for all positions in the mouth
- Triangular design for anterior implant sites and to mimic the shape of incisors and canines
- Heights and diameters are designed to correspond with final abutments to provide soft tissue sculpturing



Installation

- Select a HealDesign EV to develop the desired soft tissue anatomy.
- Pick up and install the sterile HealDesign EV directly from the blister package, using the Hex Screwdriver EV.

HealDesign EV, round

- Manually secure the healing abutment using light finger force (5-10 Ncm).

HealDesign EV, tri

- When using the two-piece triangular HealDesign EV, first seat it with a Hex Screwdriver EV.
- Rotate the abutment sleeve until the desired index position is reached.
- Manually tighten the healing abutment using light finger force (5-10 Ncm).

Two-stage surgical protocol

Cover Screw EV

- One option for each interface connection



Cover Screw EV

- Insert the Cover Screw EV using the Hex Screwdriver EV.
- Tighten with light finger force (5-10 Ncm).
- Reposition the mucoperiosteal flaps carefully and suture tightly together.

Abutment installation

- After an appropriate healing phase, expose and remove the Cover Screw EV with a Hex Driver EV.
- Install the selected healing abutment or restorative temporary/final abutment.

Note: When removing a two-piece component, keep the sleeve and screw assembled.

Step-by-step implant placement: 4.8

OsseoSpeed® EV, 6 mm



The drilling protocol for 6 mm implants is the same as for other implant lengths.



Direction Indicator EV

- Drill in the planned direction to the appropriate depth.
- When the drill ① has been used, insert the smaller end of the Direction Indicator EV into the osteotomy to visualize/verify the direction.
- See the 6 mm markings on Direction Indicator EV.
- After drill ③, use the larger end of the indicator to verify the direction.
- Drill the implant site to the appropriate depth with drill ⑤.

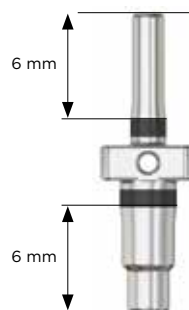

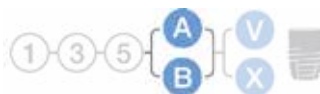
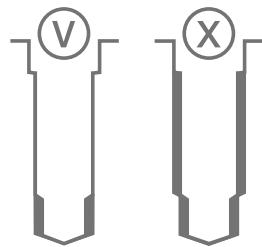

6 mm - Cortical Drill EV

- Finalize the osteotomy by drilling to the marginal end of the depth indication line. Based on cortical bone thickness, use either the cortical drill (A) or (B) specific for the 6 mm implant.



Additional spongy bone preparation

- When deemed necessary, the preparation can be performed with either of the following drills:

(V) Twist Drill EV

Following the opening of the marginal cortical layer with cortical drill (A) or (B), the (V) drill can be used to relieve the apical bone support when this support is not indicated.

(X) Step Drill EV

Following the opening of the marginal cortical layer with cortical drill (B), the (X) drill, in addition to relieving the apical bone support, is used to widen the body portion of the osteotomy in situations with more dense bone e.g. the lower jaw.

Implant Depth Gauge EV

- After drilling, use the Implant Depth Gauge EV to verify the depth of the osteotomy.

Installation

- Install the implant with the contra angle at low speed (25 rpm) and the maximum torque set to 45 Ncm.

Torque Wrench EV – surgical handling

A torque wrench together with the Surgical Driver Handle are used for implant installation and adjustment.

When used together with the Restorative Driver Handle, the torque wrench can also be used for tightening abutment screws and bridge screws.



Assemble

- Assemble the head of the wrench and the body by pushing the components together and turning until there is an audible click.

Attach

- Attach the Implant Driver EV by pressing it firmly into the Surgical Driver Handle EV.
- The driver is correctly seated when the color coded marking is just in contact with the handle.
- Pick up and install the implant.
- Insert the driver handle and implant driver into the wrench until there is an audible click.

Handling

- Use a finger on the top of the driver handle to keep it steady and in place. Then gently pull the arm of the torque wrench in the direction of the arrow until the desired torque is achieved.

Note: The arm of the torque wrench must not go beyond the end of the scale, as this could result in inaccurate torque readings.

Note: The arrow on the head of the wrench shows the direction in which the wrench is functioning.



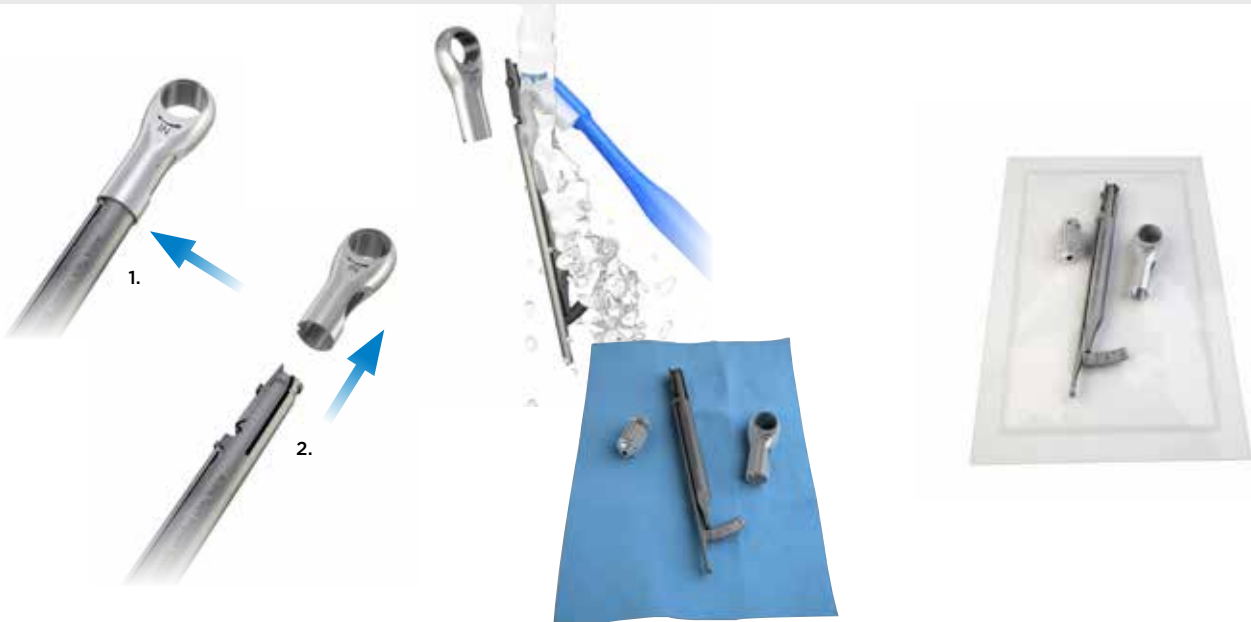

Disassemble

- Remove the driver handle from the wrench.
- Remove the head by pressing a finger into the recess (1) and gently pulling the head (2).





Cleaning and drying

- The three separated parts are now ready for cleaning using water and a brush. Let the parts dry.

Sterilization

- Follow the manufacturer's instructions for use.

Torque guide for Astra Tech Implant System® EV

Installation procedures	Recommended torque	
Implant installation	≤45 Ncm	
Healing components	Manual/light finger force (5-10 Ncm)	
Temporary restorations on all levels	15 Ncm	
Final restorations on implant level	25 Ncm	
Final restorations on abutment level	15 Ncm	

Cleaning and sterilization

All drills, except the single use Precision Drill EV, can be used approximately ten times. If drills are not reused, dispose them in a sharps container immediately after the implant procedure is completed.

Note: Single use products should not be reused.

Remove residual tissue or bone debris by immersing the used products in lukewarm water (<40°C/104°F). Do not use fixation agents or hot water as this could influence subsequent cleaning results. Products should be kept in a wet environment until the next step is initiated. For Direct Driver EV Ø 3.3, Ø 4 and Ball Abutment Driver EV storage in a wet environment is mandatory.

If cleaning is delayed more than 120 minutes, place the devices in a bath of a cleaning and disinfection solution to avoid drying of soil and/or debris, blood and other contaminations.

Preparation for cleaning

Disassembly is required for the following products:

- Large Tray EV and Small Tray EV
- Impression components (pick-ups/transfers)

Large Tray EV

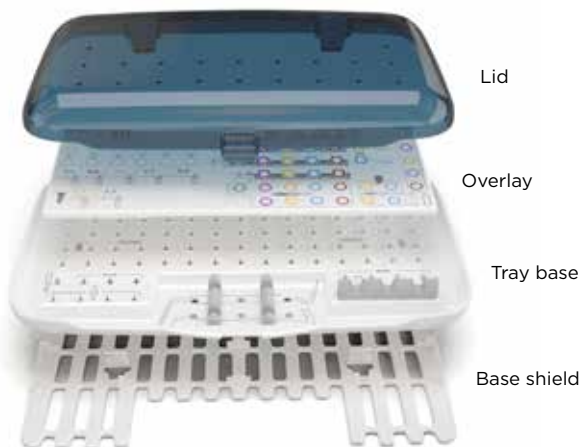

Small Tray EV



Manual procedure

Apply detergent, Neodisher MediClean-Forte (Dr. Weigert, Hamburg) or similar solution to all surfaces. Scrub the outer and, if applicable, the inner side of the product with a soft bristled nylon brush until all visible soil and/or debris are removed. Flush the inner channels/lumen with cleaning solution using an irrigation needle connected to a syringe. Check channels/lumen for residual soil and/or debris. Run the products in an ultra-sonic bath with cleaning solution for minimum ten minutes. Drills and trays excluded. Rinse under clean running water until all trace of cleaning solution is removed. Flush the inner channels/lumen with water using an irrigation needle.

Prepare a bath with a disinfection solution, D212 instrument disinfection (DÜRR SYSTEM-HYGIENE) or similar, according to the detergent manufacturer's instructions. Immerse the products completely for the time specified by the manufacturer. Flush the internal channels/lumen using an irrigation needle for a minimum of 3 times. Rinse under clean running water until all trace of disinfection solution is removed. Flush the inner channels/lumen with water using an irrigation needle.

Dry the products using medical compressed air and clean lint-free single-use wipes.

Automated procedure

Place instruments in a washer-disinfector, Vario TD or similar, according to recommendations from the supplier. Example of Vario TD washing program:

- Pre-wash, 20°C/68°F
- Cleaning with detergent, Neodisher MediClean-Forte (Dr. Weigert, Hamburg) or similar solution 45-55°C/113-131°F
- Neutralization
- Intermediate rinse
- Disinfection, >90°C/194°F (preferable 93°C/200°F), 5 min
- Drying

Inspection and function testing

Drills shall be replaced as soon as their cutting capability diminishes. Discard blunt or damaged products.

Packaging pre-sterilization

Thoroughly dry everything prior to the sterilization process to prevent the risk of corrosion. Assemble the tray and re-position the drills and instruments using drill/letter numbers, where applicable. It is recommended to wrap the instruments and tray according to the sterilization wrap manufacturer's instructions. It is recommended to place the abutments, screws, and applicable products in a sterilization bag.

Note: For US: Use FDA cleared sterilization bag and 16 minutes dry time at the end of the steam sterilization cycle.

Sterilization

Steam sterilization with a pre-vacuum cycle (134°C/275°F for 3 minutes).

Sterilization procedure for zirconia products

The products should not be sterilized in a steam autoclave. The process can affect the mechanical properties of the material.

Statement Cleaning and sterilization of Astra Tech Implant System® EV products

The cleaning and sterilization instructions for Astra Tech Implant System EV assortment has been developed and validated by Dentsply Sirona. The instructions have been developed in accordance to, with evaluated by the standards stated, please see below.

Both the VarioTD program (recommended for automated reprocessing) and the Neodisher Mediclean Forte (Dr. Weigert) detergent are recommendations and can be substituted with similar programs and detergents. For more information, please see <http://www.miele-professional.com> and/or www.drweigert.com.

Large Tray EV and Small Tray EV are made of PPSU (Polyphenylsulfone) material which may be sensitive for some chemicals containing acetate e.g. ethyl acetate. Consult your detergent manufacturer for compatibility of used detergent with PPSU if Neodisher Mediclean Forte is not used.

For ZirDesign abutment: Liquid Chemical Sterilization/ High Level Disinfection is recommended.

Note: For US: Dry heat (160°C/320°F for 4 hours) is the recommended procedure.

For Atlantis abutment in zirconia: Dry heat (160°C/320°F for 4 hours) is the recommended procedure.

Storage

The products should be stored, in their package, in a dry place, at normal temperature (18-25°C/64-77°F). Use the sterilized components within the stated time period from the sterile bag manufacturer.

Note: For maintenance and cleaning of Contra Angles and Torque Wrench EV, follow the manufacturer's instructions.



If alternative procedures are used it is the responsibility of the user to ensure that the cleaning and sterilization procedure chosen achieves the desired results.

- ANSI/AAMI ST79:2010 & A1:2010 Comprehensive guide to steam sterilization and sterility assurance in health care facilities.
- ANSI/AAMI ST81:2004/(R) 2010 Sterilization of medical devices – Information to be provided by the manufacturer for the processing of resterilizable medical devices.
- AAMI TIR12:2010 Designing, testing, and labelling reusable medical devices for reprocessing in health care facilities: A guide for medical device manufacturers.
- EN ISO 17664:2004 Sterilization of medical devices – Information to be provided by the manufacturer for the processing of resterilizable medical devices.
- EN ISO 15883-1:2009, Washer-disinfectors – Part 1: General requirements, terms and definitions and tests.
- EN ISO 15883-2:2009, Washer-disinfectors – Part 2: Requirements and tests for washer-disinfectors employing thermal disinfection for surgical instruments, anaesthetic equipment, bowls, dishes, receivers, utensils, glassware, etc.
- ISO/TS 15883-5:2005, Washer-disinfectors – Part 5: Test soils and methods for demonstrating cleaning efficacy.
- EN ISO 17665-1:2006, Sterilization of health care products – Moist heat – Part 1: Requirements for the development, validation and routine control of a sterilization process for medical devices.

About Dentsply Sirona Implants

Dentsply Sirona Implants offers comprehensive solutions for all phases of implant therapy, including Ankylos®, Astra Tech Implant System® and Xive® implant lines, digital technologies, such as Atlantis® patient-specific solutions and Simplant® guided surgery, Symbios® regenerative solutions, and professional and business development programs, such as STEPPS™. Dentsply Sirona Implants creates value for dental professionals and allows for predictable and lasting implant treatment outcomes, resulting in enhanced quality of life for patients.

About Dentsply Sirona

Dentsply Sirona is the world's largest manufacturer of professional dental products and technologies, with a 130-year history of innovation and service to the dental industry and patients worldwide. Dentsply Sirona develops, manufactures, and markets a comprehensive solutions offering including dental and oral health products as well as other consumable medical devices under a strong portfolio of world class brands. As The Dental Solutions Company™, Dentsply Sirona's products provide innovative, high-quality and effective solutions to advance patient care and deliver better, safer and faster dentistry. Dentsply Sirona's global headquarters is located in York, Pennsylvania, and the international headquarters is based in Salzburg, Austria. The company's shares are listed in the United States on NASDAQ under the symbol XRAY.

Visit www.dentsplysirona.com for more information about Dentsply Sirona and its products.